



# Newsletter of the **Aiken Model A's**

Aiken, SC

A New Chapter in an Old Story

February 2020



*Inspired by new member  
Carl Pease's  
creation. (see page 5)*

## **JANUARY BUSINESS MEETING** Tuesday, January 7

First Presbyterian Church Fellowship Hall  
Aiken, SC 7 pm  
Program: Touring Etiquette

## **A LOOK INSIDE.....**

Who, What, When, Where/For Sale .....	2
President's Column/ Minutes .....	3
Minutes/Lubrication .....	4
Going and Coming .....	5
Technical Things .....	6
AMA Newsletter Sponsors .....	7
Down the Road/Birthdays .....	8



# WHO'S WHO IN AMA?

BOD/STAFF	NAME	EMAIL
President	Greg Jones	distagon2@aol.com
Vice President	Charles Hilton	cahilton@hotmail.com
Secretary	Eric Shogren	ericshogren@gforcecable.com
Treasurer	Brian d'Entremont	brian@dentremont.us
Director at Large	Rachel d'Entremont	rachel@dentremont.us
Membership/Website	Pat Roberts	aikenmodelas@gmail.com
National Representative	Debi Paul	debi_alderman16@yahoo.com
Newsletter	Pat Roberts	patroberts1176@gmail.com
Photographer	Greg Jones	distagon2@aol.com

Club Postal Address: P. O. Box 992, Aiken, SC 29802  
 Email: aikenmodelas@gmail.com Website: www.aikenas.org

# WHAT, WHEN, WHERE??

## CARS & COFFEE

Join us Saturdays at the Village Café from 10-11 for fun, fellowship and car-talk! Solve all the world's problems here!  
 110 Coach Light Way SW  
 Aiken, SC 29803

## CLUB BUSINESS MEETINGS

Fellowship Hall,  
 First Presbyterian Church  
 224 Barnwell Ave NW,  
 Aiken, SC  
 First Tuesday of each month,  
 7 pm

## GUESTS ALWAYS WELCOME!

## FIRST SATURDAY BREAKFAST

Meet for a cooked-to-order breakfast and fellowship at the Masonic Lodge, 8:30 am on the first Saturday of each month.  
 443 Laurens St NW, Aiken, SC 29801

The Aiken Model A's is a chapter of the Model A Ford Club of America (MAFCA). We are a not-for-profit corporation,



dedicated to the preservation and the restoration of the Model A Ford automobile. Owning a Model A Ford is not required for membership; a membership application is available at [www.aikenas.org](http://www.aikenas.org).

Our annual dues are \$25; our fiscal year runs July 1-June 30.



This may not be a car photo but may still have interest. I made a hand rail for the entrance to our home.....for our Model A friends. I got the idea...my wife modified it and together we worked out details to make it work. I started with a single bumper but could not make it come out ok. She came up with the solution.  
 Bill and Jan Ewertz, Sonoma CA

## A MAFFI MINUTE



From the Model A Ford Foundation: 2020 will be a memorable year for the Model A Museum as we celebrate our 10 year anniversary. Our Museum has undergone many changes during its existence and all of them for the better. This is due to the continued enthusiasm for the Model A hobby and most of all, your continued support to keep us up and running. We are also fortunate to be a part of the Gilmore Museum Complex.

If you are making your plans for this coming year, please consider a trip to the Model A Museum for **Model A Day, September 19, 2020**. Our theme will be "First Responders of the Model A Era!" We are excited about our theme and are currently searching for service vehicles that fit our theme to be on display such as fire trucks, police cars, ambulances, and more. If you know of one or have one that you would like to showcase, please contact us.

**FOR SALE**

**1927 Model T**

**Soft Top**

**Asking \$10,000 OBO**

**Call Vance**

**803/507-8361**

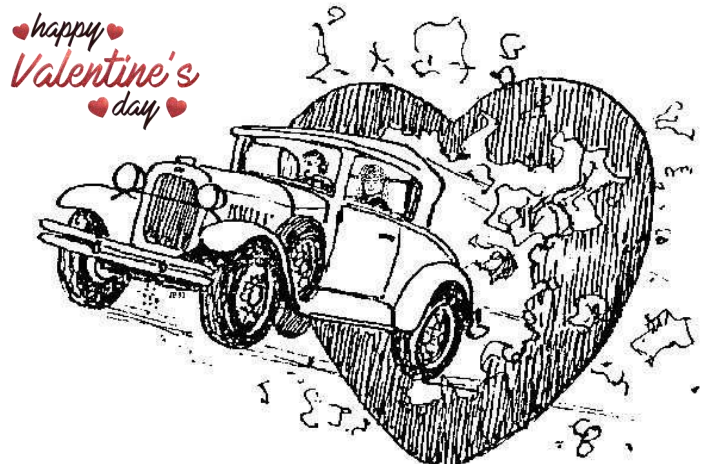



## OFF THE RUNNING BOARD

Thoughts from President Greg.....

It seems like our annual Christmas club events-the Aiken Christmas parade, the GVW parade, and the Sage Valley event-were only yesterday! However, Valentine's Day will be here before we know it! We lead busy lives, and that makes the time go by quickly. Fortunately, we carve out some time for Model A Fords.

Luckily, we don't have to deal with snow, ice, and sub-zero temperatures here in Aiken. (Well, usually not.) We have an outing planned for February 15 which is a short drive to Ridge Spring. We will meet at 10:30 am for departure to Ridge Spring and lunch at Juniper's restaurant. We went to Juniper's as our very first club outing right after formation of the Aiken Model A's. It is a short, easy, and relaxing drive from Aiken.

At our meeting in February, I would like to go over touring etiquette so that we are all on the same page. This "etiquette" is more than just simple pleasantries-there is fundamental safety involved. We need to follow protocol involving driving speeds, distance between cars, awareness of other traffic, and what steps to take if a member experiences mechanical (or other) problems. We normally tour around 45 mph which can be frustrating to someone in a modern car in a hurry to be somewhere. Therefore, being aware of what "modern" traffic is doing is of paramount importance-drivers are not always patient nowadays.

April 17-18 brings us the 15<sup>th</sup> Annual All Model A Parts Swap Meet in Greenwood, SC. This swap meet is hosted by the Old 96 District Model A Ford Club. I have found good stuff at this swap meet so I would recommend you go if you are looking for parts, or just want to get out and take it all in. It is at 314 Old Mt. Moriah Road in Greenwood, SC which is on Rt. 221 between Rt. 25 and Rt. 225.

Finally, I would like to welcome new members Carl and Ellie Pease to the club! They have relocated to Aiken from Anaheim, California. Please give Carl and Ellie a big welcome to the Aiken Model A's!

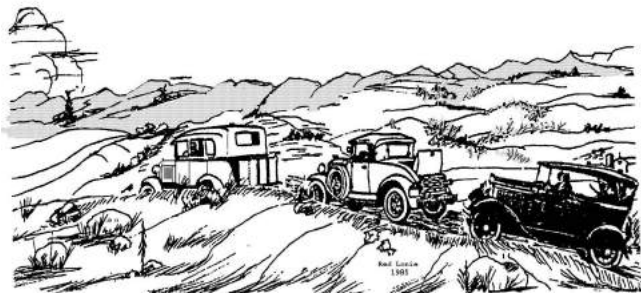

## JANUARY 7, 2020 MEETING MINUTES

Eric Shogren, Secretary

President, Greg Jones, called the meeting to order.

It was brought to the attention of the membership to keep Walker Crosby in our thoughts and prayers during this time.

The minutes from the December meeting were approved with a correction to a date published in the newsletter.

Under officer's reports, Brian d'Entremont provided the treasurer's report.

In the mailbox Rachel d'Entremont noted that 4 vendors had renewed their advertising in the newsletter.

Under recent events the Sage Valley Currier and Ives event was mentioned. The Graniteville Parade and the disorganization of the lineup locations (directing Model A's down a one way street in the wrong direction with oncoming traffic) was discussed. But overall the Aiken Model A's had a fantastic turnout for all this year's Christmas parades. Everyone also expressed appreciation for the special Cars & Coffee at Don and Dolores Cerefin's. It was really nice to see them once more before their upcoming move.

The following upcoming events were discussed:

May 2<sup>nd</sup> – Tour and Picnic at Rivers Bridge State Park

May 23<sup>rd</sup> - Aiken Memorial Day Parade

September 19<sup>th</sup> – International Model A Day

Also under upcoming events it was proposed to schedule a "Tour to Lunch" inviting other Model A clubs to join us at a destination lunch. Several destinations were proposed. The club decided the destination would be Juniper's Restaurant in Ridge Spring on February 15<sup>th</sup>. The club would depart from First Presbyterian Church at 10:30 am.

Under Other Business:

Greg Jones also noted that we need to be looking for a newsletter editor, though Pat Roberts has agreed to continue writing a more limited newsletter.

Pat Roberts' has been recognized for her work on the Aiken Model A's Newsletter from the Model A Ford Club of America (MAFCA). Pat received a certificate for "2019 Newsletter of Distinction." Way to go Pat!

Larry Lamb also shared feedback from Sage Valley on our support of their Currier and Ives Christmas dinner for their members. Sage Valley was extremely complimentary and stated that the membership really love riding to clubhouse in our Model A's. So much so, they have already requested we support the event again next year. Sage Valley was also very generous with their donation. This year's Currier and Ives was a two night event to accommodate all the members who wanted to participate. However, due to rain on Friday night, the Aiken Model A's only supported the event on Saturday night, but Sage Valley provided a generous donation as if we had been there both nights. Sage Valley management stated that the weather wasn't our fault and understood we were ready to support the Friday night event if requested. Larry also stated that 9 cars were about the perfect number to shuttle all the attendees to the clubhouse in a timely

(continued on page 4)

(continued from page 3)

manner. Larry is working with Sage Valley to set the date for the appreciation dinner Sage Valley provides in addition to their donation. It was mentioned though, that with the growth in the Aiken Model A's membership there may be a cap set on the number of members that can attend the appreciation dinner at the Sage Valley Hunting Lodge.

For the technical presentation, a round table discussion was held on Peter Srednicki's efforts to trouble shoot a knock in the engine of his 1928 Phaeton. Pete discussed how he had pulled the main bearing caps for inspection. Fortunately, he found no cracked babbit, but he removed shims to bring the clearance back down to 0.0015 of an inch. He also found that

valves were out of adjustment, with one exhaust valve at 0.008 inches verses the specified 0.015 inches.

Lew Fierke also discussed on taking his 6 volt positive ground alternator on his 1928 Leather Back Fordor for a test resulted in it being rebuilt and then literally burning up when he re-installed it and started the car. Fortunately, Lew was able to shut off the car and disconnect the battery immediately, which stopped the fire and limited damage to only the alternator. The sad thing is the rebuild may not have been necessary. The shop he took it to did not have a means of testing it so they tore it down and replaced the voltage regulator instead.

The meeting was adjourned.



### CHECK IT OUT!

If you go to our website ([www.aikenas.org](http://www.aikenas.org)) and then to the "About Us" page, you'll find that our sponsors (see this newsletter, page 7) are now there! To visit their website, you can either click on their business card or their name in the list below the cards. A few of the sponsors don't have a website, so you'll find an email address (and/or phone number), where you can contact them. See what you can discover!!

## MODEL A LUBRICATION CHART

This Model A Lubrication chart first appeared in the January 1928 Ford Service Bulletins on page 216. (see below) Most Model A suppliers can sell you a large color reproduction of the lubrication chart.

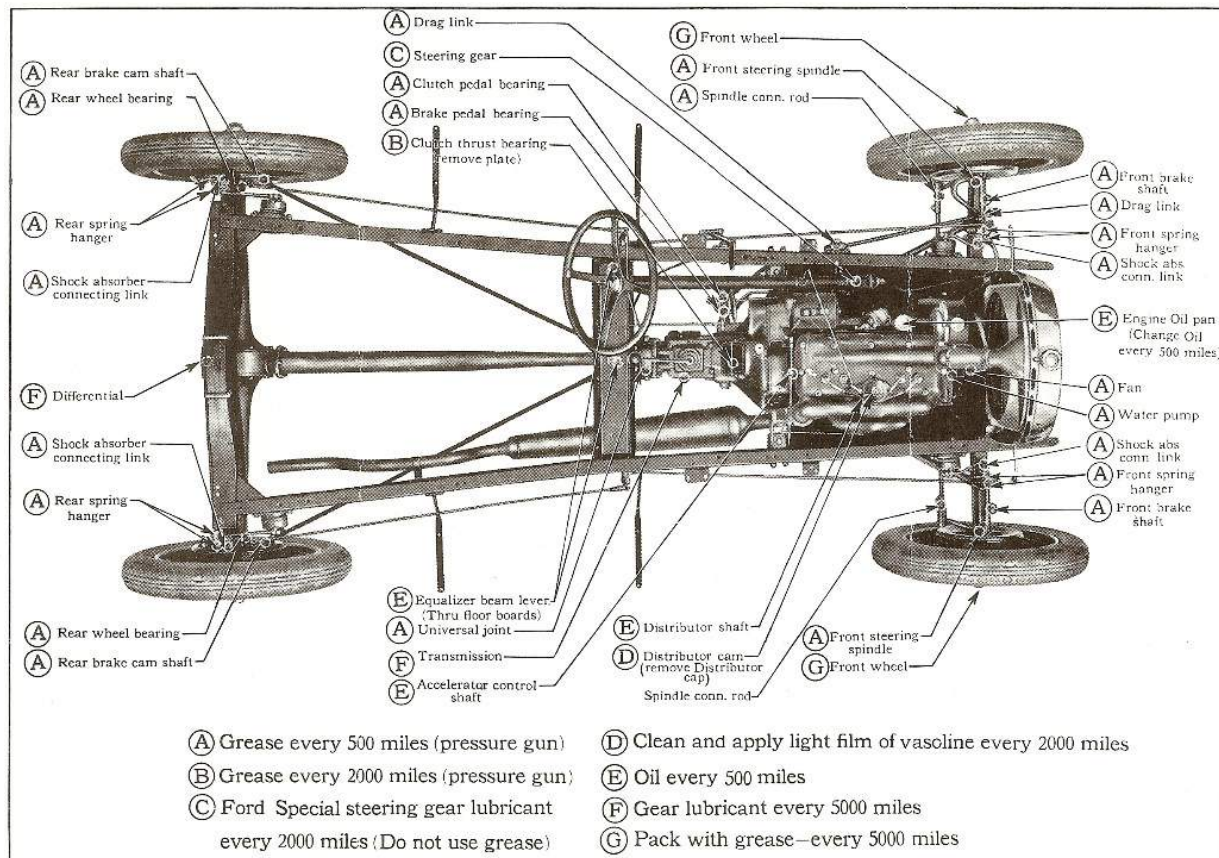

FIG. 445  
Lubrication Chart



# Going..and Coming!



## Don and Dolores Cerefin Move to Colorado



Don Cerefin (R) is getting ready for a Christmas parade - Don and Dolores, founding members of the AMAs, are moving to Colorado soon. They'll be missed!



Our members, glad to be 'of service', help Don and Dolores find new homes for some of their garage treasures!!!



## Carl and Ellie Pease Move from California

January 11 was an exciting day for us at Cars & Coffee, as we finally got to meet Carl and Ellie, who moved from Anaheim, CA to Aiken in early December. After much visiting, we 'adjourned' to the parking lot, where we met (and saw demonstrated) the vintage accessory that Carl made for their handsome '31 Fordor. Also of interest was the violin that was on the back seat! Welcome aboard, Carl & Ellie.



The policeman and his arms that extend upon braking fascinated your editor! (See cover..) Photos, d'Entremont, Roberts



# TECHNICAL THINGS

## CLEAN THOSE SPOKED WHEELS

Here is a very simple and easy way to clean spoked wheels. Buy a good brand of "Foam Bathroom Cleaner" to spray on your wheels.

After spraying, wait a few minutes to let the cleaner soak in and to penetrate the dirt.

Rinse off with a garden hose, and you should have clean and shiny wheels!



*Submitted by Tony Topicz and previously published in the AaaOOOgah newsletter, Ohio Valley Region. Illustrated by Dick Lewis, Lawrenceburg,*

### Jim's Tech Tip —from Jim Cannon, Former MAFCA Technical Director

#### Front Wheel Bearing Installation and Adjustment



1. See that front hub, inner and outer bearings are packed with grease.

2. Front hub washer should slide over threads on spindle body with fingers (loose fit).

3. Install nut and tighten it while slowly turning the brake drum so that all component parts are pulled together snugly; that is, inner and outer bearings will be snug in cones, washer is tight against outer roller bearing, and nut tight against washer. (There will be a slight drag when drum is turned.) Not over 8-10 ft-lbs of torque is required to get these results.

4. Turn nut BACK two castle slots (this is approximately ¼ turn of nut); insert cotter pin and try bearings for a slight side play and a free spinning

drum or wheel.

Don't forget the cotter pin! The nut will back out and the wheel will come off. That will totally spoil your Model A Day!



**AIKEN MODEL A'S NEWSLETTER SPONSORS**

Thanks to the following sponsors whose generosity supports this newsletter. Please remember them when you need the services they offer!





**Woody Malone**  
DRIVING YOU HOME

(803) 215-4024 cell  
(803) 502-7789 office  
woodleymalone@gmail.com

**Meybohm**  
REALTORS®

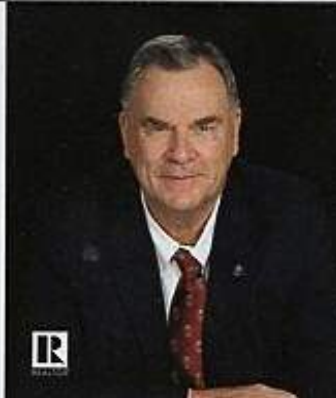
142 Laurens Street NW Aiken SC 29801  
www.meybohm.com





Call me today to insure that your classic car has the coverage that you need.

**803-642-6560**

---

**WALKER CROSBY**  
1890 Huntsman Dr., Country Square  
Aiken, SC 29803  
walkercrosby@allstate.com



Insurance subject to availability and qualifications. Allstate Fire and Casualty Insurance Co., Northbrook Indemnity Co. Northbrook, Illinois © 2012 Allstate Insurance Co.

**"ONE MILE AHEAD"**  
*Smith and Jones*  
Antique Auto Parts  
60 Wisconsin St., W. Columbia, SC 29170  
803/822-4141 FAX 803/822-8477



Quality Parts  
Same Day Shipping  
Established 1972  
142 Page Catalog  
Order Desk 800-422-1928



www.snjparts.com

The World's Largest Selection of 1909-31 Ford Parts

**Snyder's**  
ANTIQUE AUTO PARTS

12925 Woodworth Rd. • New Springfield, OH 44443  
Toll Free Ordering (888) 262-5712  
or FAX (888) 262-5713  
Order On-Line @ www.snydersantiqueauto.com



**FREE Fully Illustrated CATALOG**  
\$10.00 outside the U.S., Canada, & Mexico

**Bentley's**  
Antique Auto Service, Inc.

We are a Full Service Shop, specializing in Model A Fords  
We offer Award-Winning Paint and Bodywork  
Expert Service and a Complete Machine Shop  
Enjoy the Drive...

**678-407-1947**

**BRATTON'S**  
ANTIQUE AUTO PARTS



800-255-1929 Phone  
www.brattons.com  
800-774-1930 Fax  
1606 Back Acre Circle  
Mount Airy, MD 21771

Your source for Quality Model A Ford Parts since 1976

**Guben's Garage**



**Model A Ford Service and Repair**  
(803) 215-3276  
ericshogren@gforcecable.com

**Mike's "A" Ford-able Parts**  
**Mike Butcher**



124 Model A Drive, Maysville, GA 30558  
email: mike@mikes-afordable.com - www.mikes-afordable.com  
Fax: 706 652 2492 - Phone: 706 652 3866  
1 888 TRY MIKE (879 6453)



Specialising in 1928 - 1931 Model A Ford Parts

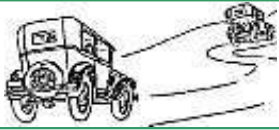

# DOWN THE ROAD....



## MONTHLY AMA HAPPENINGS

**First Saturday Breakfast**— February 1, March 7...Masonic Lodge, Aiken. (Location, page 2)

**Saturday Morning Cars and Coffee at the Village Café**—Food, fellowship, coffee and conversation. (see page 2, too)

## OUR REGIONAL HAPPENINGS

**February 15**—Road trip, lunch at Junipers in Ridge Spring –leave First Pres (Laurens Street) at 10:30 a.m.

**April 17-18** —**15th Annual All Model A Parts Swap Meet, Greenwood, SC** Hosts: Old Ninety Six District Model A Ford Club. . Admission: Adults \$2.00. Car Corral \$10.00 both days. Vendor Spaces \$25.00 Pre-Register/\$30.00 at the gate. Lunch available 11:00-2:00. Door Prizes and 50/50 Drawing Daily. Set up date: April 16. Location: 314 Old Mt. Moriah Road Greenwood SC 29646 (on Rt.221 between Rt.25 and Rt.225) **Info:** Warren Eugene Reynolds, 864-980-7937 or 864-992-3230

**May 2** —**Tour & Picnic, Rivers Bridge State Park, SC** Hosts: Shade Tree A's, Augusta, GA

**May 2**—**Trenton Peach Blossom Parade, Trenton, SC**

**May 23**—**Aiken Memorial Day Parade**

**September 19** — **International Model A Day**

## OTHER UPCOMING OPPORTUNITIES

**June 21-26** — **MAFCA National Convention** in Texas' Hill Country, Kerrville, TX Hosts: Alamo A's  
Host hotel: World-famous YO Ranch Hotel and Conference Center; check Alamo A's Website for latest details:  
<https://www.alamomodela.com/mafca-national-convention-2020.php>

**September 19** —**10th Annual Model A Day 2019 at Gilmore Car Museum** Hickory Corners, MI Hosts: MAFFI (Model A Ford Foundation) hosts the 10th Annual Model A Day at the Model A Ford Museum at the Gilmore Car Museum. Swap meet, Annual MAFFI membership meeting **Info:** MAFFI website: <http://www.maffi.org> or Jerry Morrissey, 269-615-3719



**Aiken Model A's**  
*A New Chapter  
in an Old Story!*

P. O. Box 992  
Aiken, SC 29802

(803) 649-0054  
[aikenmodelas@gmail.com](mailto:aikenmodelas@gmail.com)  
[www.aikenas.org](http://www.aikenas.org)

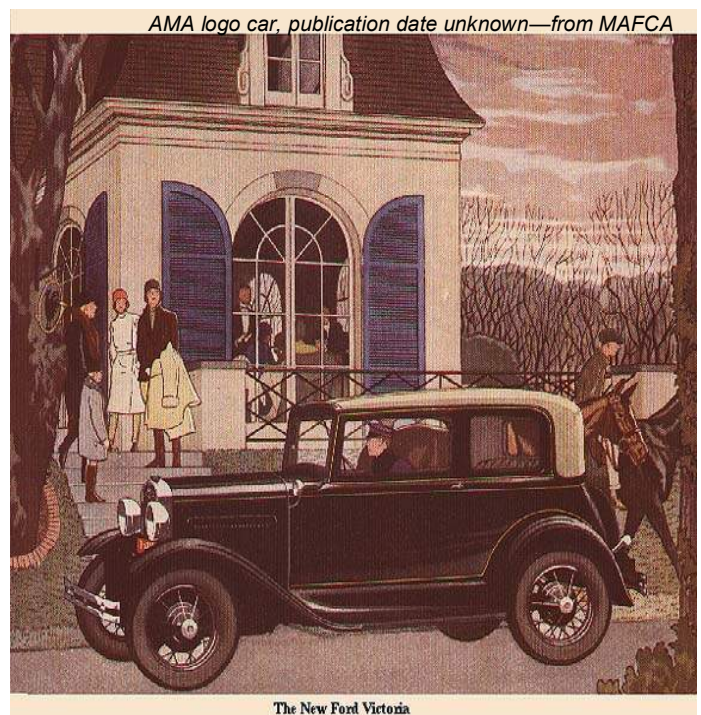

AMA logo car, publication date unknown—from MAFCA

The New Ford Victoria



**AMA  
BIRTHDAYS**

2—AllisonLynn Bond  
9—Biz Mann  
24—Craig McMullin  
28—Susan Buff  
28—Rachel d'Entremont